



SECTION 3.2_KSFH

FLAME ARRESTER EXPLOSION PROOF IN-LINE

INTRODUCTION

The model KSFH inline flame arrester is designed, manufactured, tested according to API 2000, British Standard Specification Code BS7244, and EN 12874 / ISO 16852. The units are passive devices with no moving parts. They prevent the propagation of flame from the exposed side of the unit to the protected side by the use of a 316L stainless steel crimped metal ribbon type flame cell element. This construction produces a matrix of uniform opening that are carefully constructed to quench the flame by absorbing the heat.

Operating Temperature @ Pressure

KSFH / DN 50 ~ DN 350

+ 60°C (=140°F) @ 1.1 bar abs

Body Materials Aluminium, Nodular Iron, Cast Steel, SS304, SS316, SS316L with various trims (Different materials available on request)

Sizes range DN 50 ~ DN 350 with ANSI 150lb flanges(Different connections available on request)

Rules & certifications API 2000, BS7244, and EN 12874 / ISO 16852
Flame cell : NEC group D or IEC IIA Gases(Other gas groups all available as extras)

Optimum / optional Design & Arrangements Stem Jacket type, Steam Tracing type

APPLICATION

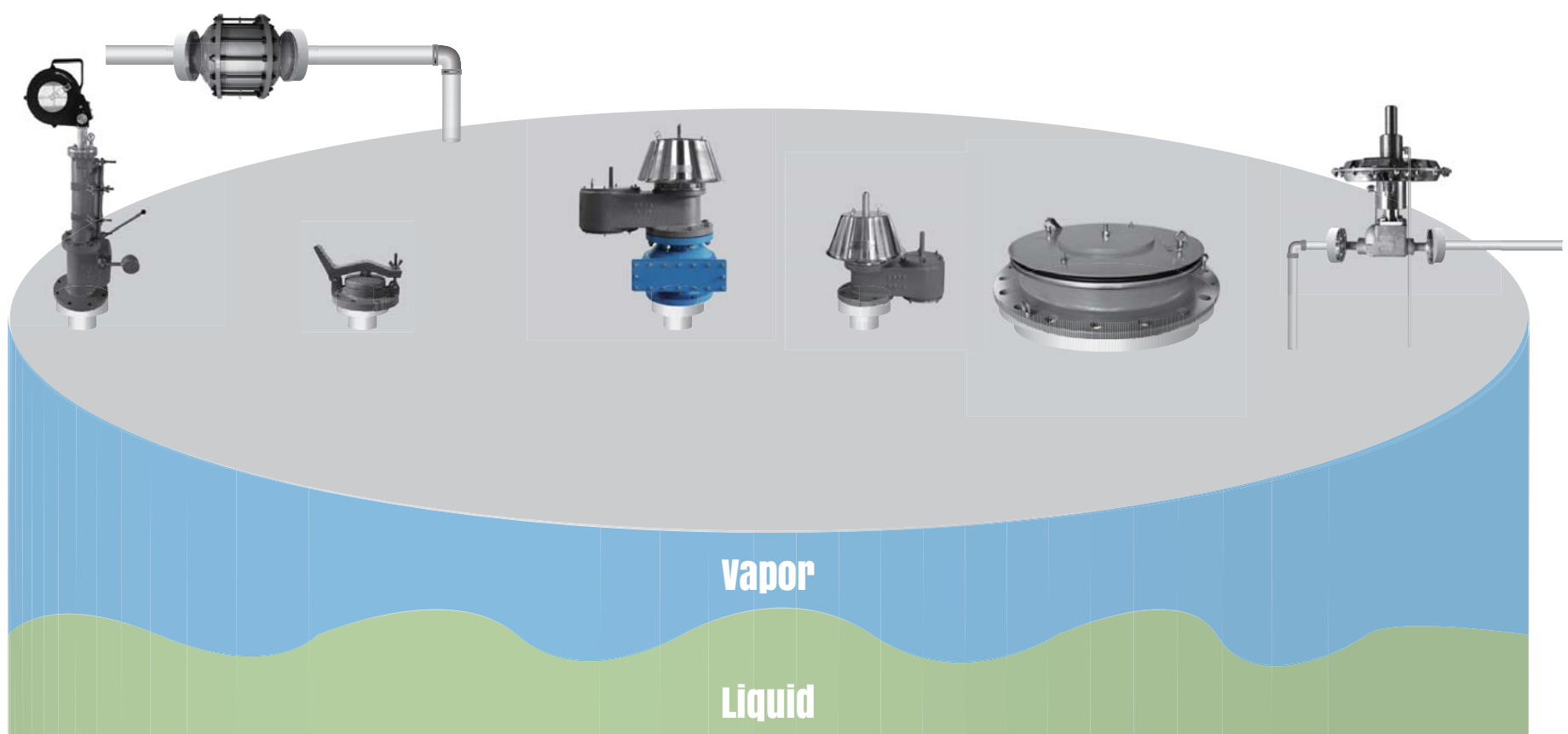

OUTLINE DRAWING

KSFH

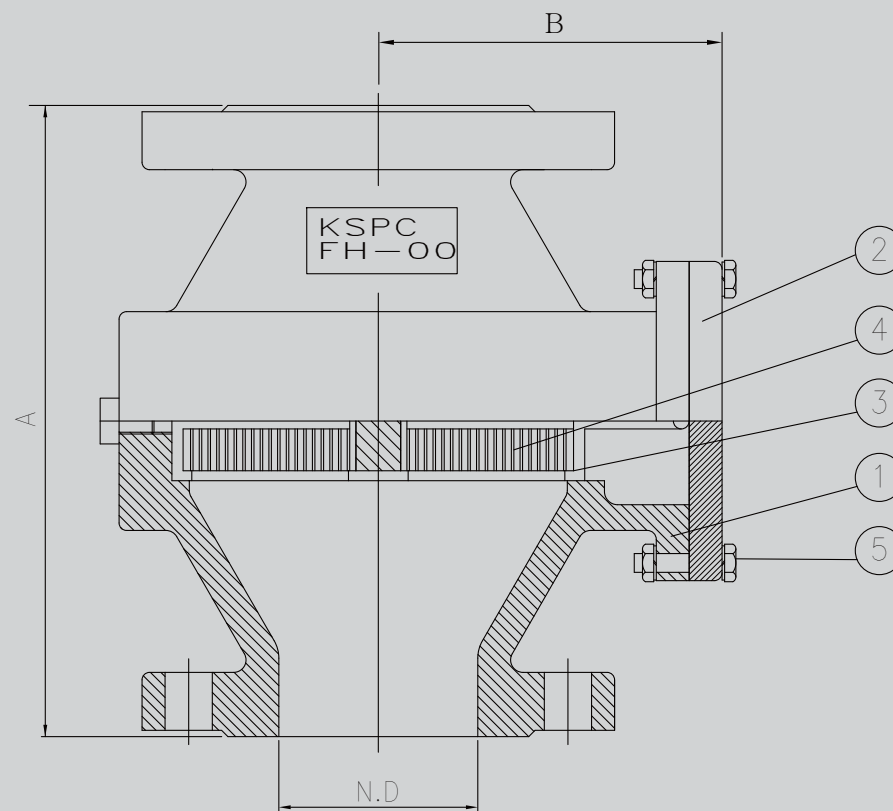

Section 3.2
KSFH

DIMENSION TABLE

SIZE	2"	3"	4"	6"	8"	10"	12"	14"
N.D	50	80	100	150	200	250	300	350
A	214	240	262	294	305	354	370	565
B	124	144	163	188	220	310	317	393

NOTE Standard Connection(ANSI 150LB flange) and JIS or different types are available upon request.

COMPONENT MATERIAL

ITEM NO	COMPONENT	ALUMINIUM	C.S	S.S
1	BODY	CAST ALUMINIUM	CAST or WELDED C.S	S.S
2	COVER	ALUMINIUM	C.S	S.S
3	ELEMENT RING	SS304	SS304	SS304 OR SS316L
4	ELEMENT	SS316L		
5	STUD BOLT/NUT	A193-B7 / A194-2H OR S.S		
STANDARD PAINTING		IN-OUT SIDE EPOXY 150 MICRON WITHOUT S.S & AL PART.		

NOTE AL – Aluminium, C.S – Carbon Steel, S.S – Stainless Steel

MAINTENANCE

- ⚠ Periodic inspection and maintenance is required. The cell assembly can be removed for cleaning purposes.
- ⚠ Cleaning can be accomplished by dipping the entire cell assembly into an appropriate solvent.
- ⚠ Care should be taken not to damage the cell openings as such deformations hamper the flow through the cell.
- ⚠ The gaskets should be inspected and replaced if necessary.